

DETAILS EXPLANATIONS**EE : Paper-2 (Paper-7) [Full Syllabus]****[PART : A]**

1. The instruments, on the basis of their functions, are classified as indicating, recording and integrating instruments.
2. Shunt is required to increase the range of an ammeter. Shunt resistance may be calculated using the following expression :

$$R_s = \frac{R_m}{(I/I_m) - 1} = \frac{R_m}{N - 1}$$

where N is multiplying power of shunt.

3. The accuracy of a CT may be improved, at least with respect to transformation ratio, by modification of the ratio of turns. Correction can be made by a small reduction in secondary turns. The transformer so corrected may be marked as compensated.
4. Clock meters can be used on both AC and DC systems. These are not affected by external stray magnetic field and are comparatively free from temperature, frequency and waveform errors. These meters are very accurate on small loads.
5. Main disadvantage of average reading voltmeters is that they operate in audio frequency range. In radio frequency range, distributed capacitance of the high resistance R introduces error in the reading. Another disadvantage of such a voltmeter is that due to nonlinear voltampere characteristic for lower voltage the readings of the voltmeter at lower voltage are not correct.
6. Coating of a conducting material, known as aquadag, is provided over the interior surface of CRT in order to accelerate the electron beam after passing between the deflection plates and to collect the electrons produced by secondary emission when electron beam strikes the screen.
7. The synchroscope is an instrument for indicating differences of phases and frequency between two voltages. It is essentially a split phase motor in which torque is developed if the two voltages applied differ in frequency. It is used for synchronisation of alternators.
8. Average value of V_o of 1- ϕ one pulse converter is

$$V_o = \frac{V_m}{2\pi} (1 + \cos \alpha), \text{ Given that}$$

$$V_o = \frac{V_m}{2\pi}, \text{ So that } (1 + \cos \alpha) = 1$$

$$\cos \alpha = 0 \Rightarrow \alpha = \frac{\pi}{2}$$

we know that input p.f.

$$= \sqrt{\frac{(\pi - \alpha) + (\sin 2\alpha / 2)}{2\pi}} = \sqrt{\frac{(\pi - \pi / 2) + (\sin \pi / 2)}{2\pi}}$$

Input p.f. = 0.5 lagg.

RMS value of output voltage

$$V_{\text{orms}} = \frac{V_m}{2} \sqrt{\frac{(\pi - \alpha) + (\sin 2\alpha / 2)}{\pi}}$$

$$V_{\text{orms}} = \frac{V_m}{2} \sqrt{\frac{(\pi / 2) + 0}{\pi}} = \frac{V_m}{2\sqrt{2}}$$

$$\text{Ripple factor} = \sqrt{\left(\frac{V_{\text{orms}}}{V_o}\right)^2} - 1 = \sqrt{\frac{\pi^2}{2}} - 1 = 1.98$$

9. Holding Current (I_H) : It is a minimum value of anode current below which thyristor will returned to forward blocking state or thyristor will turn off.

Latching Current (I_L) : It is a minimum value of anode current required during turn on process to maintain conduction when gate signal is removed.

$$\Rightarrow I_{\text{Latching}} > I_{\text{Holding}}, I_L = (1.3 \text{ to } 3)I_{\text{Holding}}$$

10. At $\theta = \beta$, $V_o = 0$ and $i_o = 0$, angle β is called the extinction angle and $(\beta - \alpha) = \gamma$ is called conduction angle.

\Rightarrow Circuit turn off time

$$t_c = \frac{2\pi - \beta}{\omega} \text{ sec}$$

for natural commutation or line commutation, t_c should be more than t_q the thyristor turn off time.

$$\Rightarrow V_{o \text{ avg}} = \frac{1}{2\pi} \int_0^{2\pi} V_o d\theta = \frac{V_m}{2\pi} \int_{\alpha}^{\beta} \sin\theta d\theta = \frac{V_m}{2\pi} [\cos\alpha - \cos\beta]$$

\Rightarrow Rms output voltage

$$V_{\text{or}} = \left[\frac{1}{2\pi} \int_{\alpha}^{\beta} V_m^2 \sin^2 \theta d\theta \right]^{1/2}$$

$$V_{\text{or}} = \frac{V_m}{2\sqrt{\pi}} \left[(\beta - \alpha) - \frac{1}{2} \{ \sin 2\beta - \sin 2\alpha \} \right]^{1/2}$$

11. In fast recovery diode the layers are doped with gold or platinum. Gold or platinum doping reduces the lifetime of charge carriers and increases the recombination speed. This reduces the reverse recovery time. The ON state voltage drop is increased when it is doped with gold and platinum.

t_{rr} : Reverse Recovery Time = 5 μ s (or Less)

I_{rating} : 1A to several hundred of Amp.

V_{rating} : 50 V to 3kV

Uses : Inverter and Chopper.

12. If α is larger than 90° the direction of power flow through converter will reverse provided there exists a power source in the DC side of suitable polarity. The converter in that case is said to be operating in the inverting mode.

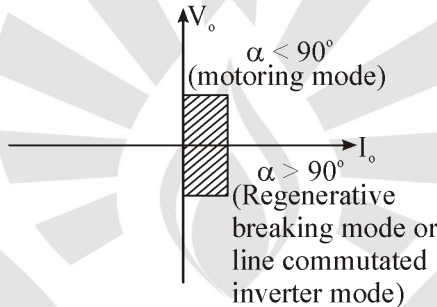
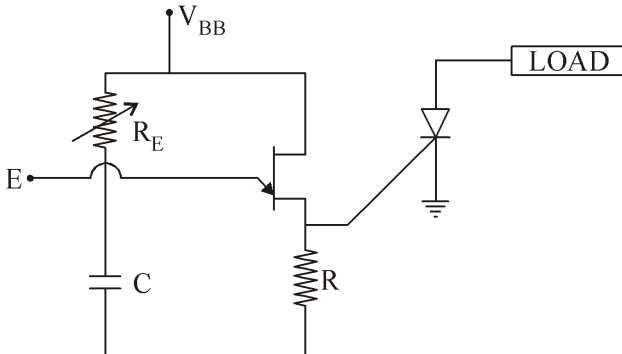

Figure : Two Quadrant operation

This mean, when $\alpha > 90$ and EMF source on DC side E reversed.
 $V_o = -ve$ and $I_o = +ve$,
 $P_o = V_o I_o = -ve$
 Net power flow from load to source i.e., inverter mode or regenerative braking mode.

- 13.



One common application of the UJT is the triggering of the other devices such as the SCR, TRIAC etc.

For ensuring turn ON UJT $R_E < V_{BB} - V_P/I_P$

The capacitor C determines the time interval between triggering pulses and the time duration of each pulse by varying R_E , we can change the time constant RC and alter the point at which the UJT fires. This allows us to control the conduction angle of the SCR.

14. $k_p = \lim_{s \rightarrow 0} G(s) = \infty$

$$k_v = \lim_{s \rightarrow 0} sG(s) = \infty$$

$$k_a = \lim_{s \rightarrow 0} s^2G(s) = \frac{k}{6}$$

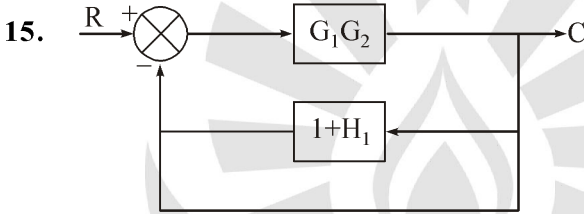

$$\frac{C}{R} = \frac{G_1G_2}{1+G_1G_2(1+H_1)}$$

16. Loop is including total DCX, MOV, ORA and JNZ instruction which have total 24 T-States

$$2384 H = (9092)_{10}$$

Give system clock = 0.5 μ s

The delay of loop

$$= (0.5 \times 0.24 \times (9092)_{10})$$

$$= 109 \text{ ms}$$

17. Channel is only the big cause of noise because it distort the signal in two ways (i) magnitude distortion (ii) phase distortion.

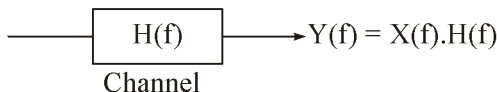

$$Y(f) = \underbrace{|X(f)||H(f)|}_{\text{Amplitude distortion}} \underbrace{\angle\theta_x + \theta_h}_{\text{Phase distortion}}$$

18. Characteristic equation

$$s + 0.1s + 1 = 0$$

$$2\varepsilon\omega_n = 0.1$$

$$\omega_n^2 = 1$$

$$\varepsilon = 0.05$$

$$\text{Setting time } t_s = \frac{3}{\varepsilon\omega_n} \rightarrow \text{for 5\% tolerance}$$

$$= \frac{3}{0.05} = 60 \text{ sec}$$

19. The decimal number :

16	423	
16	26	7
	1	A

$$(423)_{10} = (1A7)_{16}$$

20.

$$A = \begin{bmatrix} 0 & 2 \\ 8 & 0 \end{bmatrix}$$

Poles of the system can be obtained by

$$|sI - A| = 0$$

$$\begin{vmatrix} s & -2 \\ -8 & s \end{vmatrix} = 0$$

$$s^2 - 16 = 0$$

$$s = \pm 4$$

[PART : B]

21. The following standard SOP :

	BC			
A	00	01	11	10
0	1	1	1	
1	1	1		

$$F = \bar{B} + \bar{A}C$$

$$F = \bar{B} + \bar{A}C$$

22. • These is limitation of min. ON-duration

$$T_{ON(\min)} = t_2 = \frac{\pi}{\omega_o} = \pi\sqrt{LC}$$

$$So, \delta_{(min)} = \frac{T_{ON(min)}}{T} = \pi f \sqrt{LC}$$

Hence $\delta > \delta_{(min)}$

- Peak output voltage = $2 V_s$. So peak inverse voltage for FD $PIV = 2V_s$ (instead of V_s)
- $\Delta t_s \ll T_{OFF}$ i.e., C must charge from $-v_s$ to $+v_s$ quickly.

$$\Delta t_s = \frac{2CV_s}{I_o}$$

At No load or light load i.e., $I_o \approx 0$

So, that Δt_s will be very large so C will not be able to charge quickly i.e., voltage commutated chopper can not be operated at no load.

- 23.** In forced commutation, external elements L and C which don't carry the load current continuously are used to turn off a conducting thyristor.

Exp. Inverter (DC \rightarrow AC)

Chopper (DC \rightarrow DC)

Forced commutation can be achieved in two ways.

- 1. Voltage Commutation :** Conducting thyristor is commutated by the application of large reverse voltage. This reverse voltage is usually applied by switching a previously charged capacitor.
- 2. Current Commutation :** External pulse of current greater than the load current is passed in the reversed direction through the conducting SCR. When the current pulse attains a value equal to the load current, net pulse current through thyristor becomes zero and the device is turned off.

- 24.** Fourier series analysis of phase voltage

$$V_p = V_{an} = \sum_{n=1,5,7} \frac{2V_s}{n\pi} \cos \frac{n\pi}{6} \sin n \left(\omega t + \frac{\pi}{6} \right)$$

RMS value of fundamental component

$$V_{P1 \text{ rms}} = \frac{2V_s}{\sqrt{2}\pi} \times \frac{\sqrt{3}}{2} = \frac{V_s}{\pi} \sqrt{\frac{3}{2}}$$

Fourier analysis of line voltage

$$V_{ab} = \sum_{n=1,5,7,11} \frac{3V_s}{n\pi} \sin n \left(\omega t + \frac{\pi}{3} \right)$$

RMS value of fundamental line component

$$V_{L1 \text{ rms}} = \frac{3V_s}{\sqrt{2}\pi}$$

$$\text{CDF} = \frac{V_{\text{lms}}}{V_{\text{orms}}} = \frac{\frac{3}{\sqrt{2}} \frac{V_s}{\pi}}{\frac{V_s}{\sqrt{2}}} = \frac{3}{\pi}$$

Total harmonic distortion

$$\text{THD} = \sqrt{\frac{1}{(\text{CDF})^2} - 1} = \sqrt{\frac{\pi^2}{9} - 1}$$

25. For 5% tolerance

$$t_s = \frac{3}{\varepsilon\omega_n}$$

$$0.6 = \frac{3}{\varepsilon\omega_n}$$

$$\varepsilon\omega_n = 5$$

$$\varepsilon = 0.707$$

Given, $s = -\varepsilon\omega_n \pm j\omega_n\sqrt{1-\varepsilon^2} = -5 \pm j5$

26. For unit ramp input, error $e_{ss} = \frac{1}{k_v}$

$$k_v = \lim_{s \rightarrow 0} sG(s)H(s)$$

$$\frac{C(s)}{R(s)} = \frac{ks + \beta}{s^2 + s\alpha + \beta}$$

$$G(s) = \frac{ks + \beta}{s^2 + s(\alpha - k)}$$

$$k_v = \lim_{s \rightarrow 0} \frac{s \cdot (ks + \beta)}{s[s + (\alpha - k)]} = \frac{\beta}{\alpha - k}$$

$$e_{ss} = \frac{1}{k_v} = \frac{\alpha - k}{\beta}$$

27.

$$I_C = 8 \text{ A}$$

$$I_t = 8.33 \text{ A}$$

(i) $I_t = I_c \sqrt{1 + \frac{m^2}{2}}$

$$8.33 = 8 \sqrt{1 + \frac{m^2}{2}}$$

$$\Rightarrow 1 + \frac{m^2}{2} = \left(\frac{8.33}{8}\right)^2$$

$$m = \sqrt{\left[\left(\frac{8.33}{8}\right)^2 - 1\right] \times 2} = 68.2\%$$

$$(ii) \quad I_t = \sqrt{\left(1 + \frac{0.8^2}{2}\right)} = 8\sqrt{1+0.32}$$

$$= 8\sqrt{1.32} = 9.19 \text{ A}$$

28. A general expression for the transfer function of a second order control system is given by

$$\frac{C(s)}{R(s)} = \frac{\omega_n^2}{s^2 + 2\varepsilon\omega_n s + \omega_n^2}$$

As the input is an unit step function

$$r(t) = 1 \text{ and } R(s) = \frac{1}{s}$$

$$\therefore C(s) = \frac{1}{s} \cdot \frac{\omega_n^2}{s^2 + 2\varepsilon\omega_n s + \omega_n^2}$$

$$= \frac{1}{s} - \frac{s + 2\varepsilon\omega_n}{(s + \varepsilon\omega_n)^2 + \omega_d^2}$$

$$\text{where, } \omega_d = \omega_n \sqrt{1 - \varepsilon^2}$$

$$= \frac{1}{s} - \frac{s + \varepsilon\omega_n}{(s + \varepsilon\omega_n)^2 + \omega_d^2} - \frac{\varepsilon\omega_n}{\omega_d} \cdot \frac{\omega_d}{(s + \varepsilon\omega_n)^2 + \omega_d^2}$$

Taking laplace inverse on both sides.

$$C(t) = 1 - e^{-\varepsilon\omega_n t} \cdot \cos \omega_d t - \frac{\varepsilon\omega_n}{\omega_d} \cdot e^{-\varepsilon\omega_n t} \sin \omega_d t$$

$$C(t) = 1 - \frac{e^{-\varepsilon\omega_n t}}{\sqrt{1 - \varepsilon^2}} \cdot \sin(\omega_d t + \phi)$$

$$\text{where, } \phi = \tan^{-1} \left(\frac{\sqrt{1 - \varepsilon^2}}{\varepsilon} \right)$$

29. $V = 240 \text{ V}; k = 400 \frac{\text{rev}}{\text{kwh}}$
 $I = 10 \text{ A}; \text{p.f.} = 0.8$
 $p = 240 \times 10 \times 0.8$
 $p = 1920 \text{ W}$
 $p = 1.92 \text{ kW}$

Speed of Disk = $400 \times 1.92 \frac{\text{rev}}{\text{h}}$
 $= 768 \frac{\text{rev}}{\text{h}} = 12.8 \text{ rpm}$

30. Unknown resistance,

$$R = \frac{P}{Q} \times S = \frac{100}{100} \times 230 = 230 \Omega$$

Relative limiting error of unknown resistance,

$$\frac{\delta R}{R} = \frac{\delta P}{P} + \frac{\delta Q}{Q} + \frac{\delta S}{S}$$

$$= (\pm 0.02 \pm 0.02 \pm 0.01)\%$$

$$= \pm 0.05\%$$

So limiting values of unknown resistance

$$= 230 \pm 0.05\%$$

$$= (230 \pm 0.115) \Omega$$

i.e. 229.885 to 230.115

31. Power $P = \text{Voltage} \times \text{Current}$
 $= VI = 110.2 \times 5.3 = 584 \text{ W}$

Now $P = VI$

$$\therefore \frac{\partial P}{\partial V} = I = 5.3$$

and $\frac{\partial P}{\partial I} = V = 110.2$

$$w_v = 500.2$$

and $w_I = \pm 0.06$

\therefore Uncertainty in power

$$= \sqrt{\left(\frac{\partial P}{\partial V}\right)^2 w_v^2 + \left(\frac{\partial P}{\partial I}\right)^2 w_I^2}$$

$$= \sqrt{(5.3)^2 \times (0.2)^2 + (110.2)^2 + (0.06)^2}$$

$$= \pm 6.7 \text{ W} = \pm \frac{6.7}{584} \times 100 = \pm 1.15\%$$

32. Ideally the sensitivity of the detector should be sufficient but not too high for whatever precision is required in the bridge balance. Too much sensitivity is not only economically unsound but is undesirable in that it increases the difficulty of the balancing operation, by requiring very close adjustments of the bridge parameters that are altered to balance the bridge. Also it frequently implies a troublesome degree of instability in the response to the bridge adjustment and in the operation of the detector.

[PART : C]

33. Decade a is set at 4000Ω and therefore,

$$\text{error} = \pm 4000 \times \frac{0.1}{100} = \pm 4 \Omega$$

Decade b is set at 600Ω and therefore,

$$\text{error} = \pm 600 \times \frac{0.1}{100} = \pm 0.6 \Omega$$

Similarly, error in decade c

$$= \pm 30 \times \frac{0.5}{100} = \pm 0.15 \Omega$$

and error in decade d

$$= \pm 9 \times \frac{1}{100} = \pm 0.09 \Omega$$

Hence total error

$$= \pm(4 + 0.6 + 0.15 + 0.09) \\ = 4.84 \Omega$$

Relative limiting error

$$\varepsilon_r = \pm \frac{4.84}{4639} = \pm 0.00104$$

Percentage limiting error

$$\% \varepsilon_r = \pm (0.00104 \times 100) \\ = \pm 0.104\%$$

Limiting values of resistance

$$A_a = 4639(1 \pm 0.00104) \\ = 4639 \pm 5 \Omega$$

34. In figure when switch S is closed at $\omega t = 0$, the equation governing the behaviour of the circuit is

$$i_o = C \frac{dV_s}{dt} = C \frac{d}{dt} (V_m \sin \omega t)$$

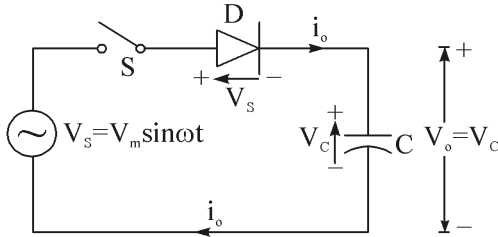

Figure (a)

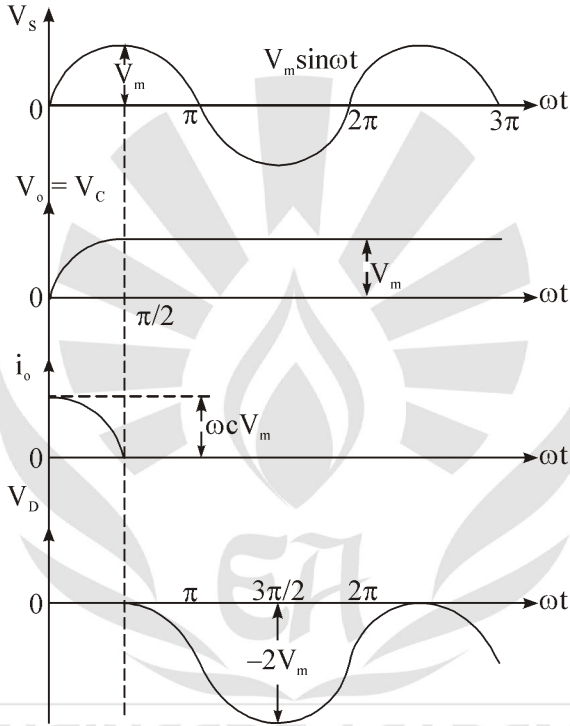

Figure (b)

Figure Single Phase half wave diode rectifier with C load (a) Circuit diagram (b) Wave forms

$$i_o = \omega C V_m \cos \omega t$$

output voltage

$$V_o = \frac{1}{C} \int i dt = V_m \sin \omega t = V_s = V_c$$

Capcitor is charged to voltage V_m at $\omega t = \frac{\pi}{2}$ and subsequently this voltage remains constant at V_m . This is shown as $V_o = V_c$ in figure.

Capcitor current or load current is maximum at $\omega t = 0$. Its value at $\omega t = 0$ is $\omega C V_m$ of shown.

The diode conducts for $\frac{\pi}{2\omega}$ sec only from $\omega t = 0$ to $\omega t = \frac{\pi}{2}$.

During this interval, diode voltage is therefore, zero after $\omega t = \frac{\pi}{2}$, diode voltage V_D is given by $V_D = -V_o + V_s = -V_m + V_m \sin \omega t = V(\sin \omega t - 1)$ from above equation the time origin is redefined at $\omega t = \frac{\pi}{2}$.

After $\omega t = \frac{\pi}{2}$, diode voltage is platted as shown in figure(b) at $\omega t = \frac{3\pi}{2}$, $V_D = 2V_m$, Average value of voltage across diode

$$V_D = \frac{1}{2\pi} \int_0^{2\pi} V_m (\sin \omega t - 1) d(\omega t) = V_m = \sqrt{2} V_s$$

RMS value of fundamental component of voltage across diode

$$V_{1r} = \left[\frac{1}{2\pi} \int_0^{2\pi} V_m^2 \sin^2 \omega t d(\omega t) \right]^{1/2} = \frac{V_m}{\sqrt{2}}$$

RMS value of voltage across diode

$$= \sqrt{V_D^2 + V_{1r}^2} = 1.225 V_m$$

35. Transfer function = $C(SI - A)^{-1} B + D$

$$A = \begin{bmatrix} 0 & 0 & -20 \\ 1 & 0 & -24 \\ 0 & 0 & -9 \end{bmatrix}$$

$$B = \begin{bmatrix} 3 \\ 1 \\ 0 \end{bmatrix}$$

$$C = [0 \ 0 \ 1]$$

$$[SI - A] = \begin{bmatrix} s & 0 & 20 \\ -1 & s & 24 \\ 0 & -1 & s+9 \end{bmatrix}$$

$$[SI - A]^{-1} = \frac{\text{Adj} [SI - A]}{\text{Det} [SI - A]}$$

$$= \frac{\begin{bmatrix} s^2 + 9s + 24 & -20 & -20s \\ s + 9 & s(s + 9) & -(24s + 20) \\ 1 & s & s^2 \end{bmatrix}}{s[s(s + 9) + 24] + 20}$$

$$= \frac{\begin{bmatrix} s^2 + 9s + 24 & -20 & -20s \\ s + 9 & s(s + 9) & -(24s + 20) \\ 1 & s & s^2 \end{bmatrix}}{s^3 + 9s^2 + 24s + 20}$$

Transfer function = $C(SI - A)^{-1} B + D$

Transfer function

$$= [0 \ 0 \ 1] \frac{\begin{bmatrix} s^2 + 9s + 24 & -20 & -20s \\ s + 9 & s(s + 9) & -(24s + 20) \\ 1 & s & s^2 \end{bmatrix} \begin{bmatrix} 3 \\ 1 \\ 0 \end{bmatrix}}{(s^3 + 9s^2 + 24s + 20)}$$

$$= \frac{\begin{bmatrix} 1 & s & s^2 \end{bmatrix}}{(s^3 + 9s^2 + 24s + 20)} \begin{bmatrix} 3 \\ 1 \\ 0 \end{bmatrix}$$

$$= \frac{s + 3}{(s^3 + 9s^2 + 24s + 20)}$$

36. The input voltage to converter

$$V_i = 100\sqrt{2} \sin 100\pi t \text{ volt}$$

The input current drawn

$$i_i = 10\sqrt{2} \sin\left(100\pi t - \frac{\pi}{3}\right) + 5\sqrt{2} \sin\left(300\pi t + \frac{\pi}{4}\right) + 2\sqrt{2} \sin\left(500\pi t - \frac{\pi}{6}\right) \text{ Amp}$$

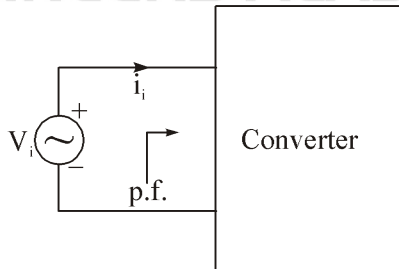

The instantaneous power

$$P = V(t) \times i(t)$$

It can be proved that the average power over one cycle is zero for different frequency voltage and current-the average power is only due to same frequency voltage is

$$P_{av} = V_{rms} I_{rms} \cos \phi$$

where, ϕ = Phase angle

Fundamental components, frequency

$$f = 50 \text{ Hz}$$

$$\omega = 2\pi f = 100\pi$$

$$V_{1rms} = 100 \text{ V}$$

$$I_{1rms} = 10 \text{ A}$$

$$\phi = \frac{\pi}{3} = 60$$

The average power for fundamental

$$P_{av1} = V_{1rms} I_{1rms} \cos \phi = 500 \text{ W}$$

as 3rd and 5th harmonics in voltage are absent

$$V_3 = 0 \text{ and } V_5 = 0$$

So avg power

$$P_{av3} = 0 \text{ and } P_{av5} = 0$$

Total power drawn from supply

$$P = 500 \text{ W}$$

The input power factor (IPF) is

$$= \frac{\text{Power drawn from supply}}{\text{Supply Average}} = \frac{P}{S}$$

rms of supply voltage

$$V_s = 100 \text{ V}$$

Total rms of supply current

$$= \sqrt{I_{1rms}^2 + I_{3rms}^2 + I_{5rms}^2}$$

$$I = \sqrt{(10)^2 + (5)^2 + (2)^2} = 11.36 \text{ Amp}$$

Supply

$$VA^5(S) = V_s I_s = 100 \times 11.36 = 1136 \text{ VAmp}$$

$$IPF = \frac{P}{S} = \frac{500}{1136} = 0.44 \text{ lagging}$$

37. All roots are equal at break away point. Break away point can be calculated as

$$\frac{dk}{ds} = 0$$

Characteristic equation

$$1 + G(s) = 0$$

$$s^2(s+12) + k\left(s + \frac{4}{3}\right) = 0$$

$$k = -\frac{s^2(s+12)}{\left(s + \frac{4}{3}\right)}$$

$$\therefore \frac{dk}{ds} = \frac{-\left(s + \frac{4}{3}\right)(3s + 24s) - s^2(s+12)}{\left(s + \frac{4}{3}\right)^2}$$

$$\frac{dk}{ds} = 0$$

$$s[s^2 + 8s + 16] = 0$$

$$s = 0, -4, -4$$

Break away point = -4

$$\text{Hence, } k(s = -4) = \frac{4 \times 4 \times 8}{4 - \frac{4}{3}} = 48$$

38. Applying the first condition of balance required for magnitude i.e.

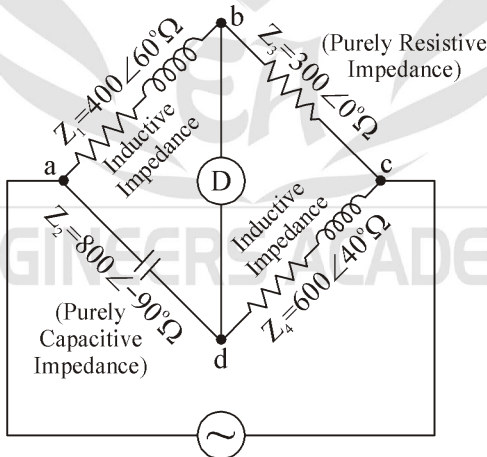

$$Z_1 Z_4 = Z_2 Z_3$$

Now $Z_1 Z_4 = 400 \times 600 = 240,000$

and $Z_2 Z_3 = 800 \times 300 = 240,000$

Thus the first condition is satisfied.

Applying the second condition required for phase angle i.e.

$$\angle\theta_1 + \angle\theta_4 = \angle\theta_2 + \angle\theta_3$$

$$\text{Now } \angle\theta_1 + \angle\theta_4 = 60^\circ + 40^\circ = 100^\circ$$

$$\text{Now } \angle\theta_2 + \angle\theta_3 = -90^\circ + 0^\circ = -90^\circ$$

i.e., second condition is not satisfied.

It means that bridge is unbalanced though the first condition for equality of magnitude products is satisfied. Obviously balance is not possible under above conditions.

$$39. \quad (i) \quad A_c + A_m = 150 \quad \dots(1)$$

$$A_c - A_m = 30 \quad \dots(2)$$

By solving equation (1) and (2)

$$A_c = 90$$

$$A_m = 60$$

$$m = \frac{6}{9} = \frac{2}{3}$$

$$(ii) \quad P_T = \frac{A_c^2}{2} \left[1 + \frac{m^2}{2} \right]$$

$$P_T = \frac{90^2}{2} \left[1 + \frac{4}{2 \times 9} \right] = \frac{90^2}{2} \left[1 + \frac{2}{9} \right]$$

$$= \frac{90^2}{2} \times \frac{11}{9} = 4950 \text{ W}$$

$$(iii) \text{ Peak envelope power} = \frac{e_{\max}^2}{2} = \frac{150 \times 150}{2} = 11250 \text{ V}^2$$

(iv) Let the additional carrier is $A'_c \cos \omega_c t$

$$S'(t) = A_c(1 + \mu \cos \omega_m t) \cos \omega_c t + A'_c \cos \omega_c t$$

$$= [A_c(1 + \mu \cos \omega_m t) + A'_c] \cos \omega_c t$$

$$= \left[(A_c + A'_c) \left(1 + \frac{A_m}{A_c + A'_c} \cos \omega_m t \right) \right] \cos \omega_c t$$

$$m_{\text{new}} = \frac{A_m}{A_c + A'_c} = 0.2$$

$$A'_c = 210 \text{ V}$$

